



VETTE SET

Volume 63 Issue 08 June 2026

Save The Wave





The Vette Set

Colorado Springs Corvette Club, Inc.
Monthly Newsletter

Volume 63 Issue 08 June 2026

"The general purpose of Colorado Springs Corvette Club (CSCC) is to encourage planned trips, events and social activities for members of CSCC; to act as a source of technical information; to establish rules and regulations covering all activities of CSCC; to provide and regulate events and exhibitions of Corvettes; and to encourage careful and skillful driving on public highways; and to own personal property as needed for the foregoing purposes."

TABLE OF CONTENTS

• <u>CLUB AND MEETING INFORMATION</u>	<u>PAGE 3</u>
• <u>RECENT MEETING MINUTES</u>	<u>PAGE 4</u>
• <u>LATEST CLUB CALENDAR</u>	<u>PAGE 5</u>
• <u>IN MEMORIAM</u>	<u>PAGE 6</u>
• <u>MY FIRST CAR</u>	<u>PAGE 8</u>
• <u>BOCHNAK'S ZR1 MUSEUM DELIVERY</u>	<u>PAGE 9</u>
• <u>CONE ZONE AUTOCROSS 2026</u>	<u>PAGE 11</u>
• <u>BOWTIES ON BROADWAY</u>	<u>PAGE 14</u>
• <u>MAY 2026 REGIONAL EVENTS</u>	<u>PAGE 17</u>
• <u>2026 CORVETTE PRODUCTION NEWS</u>	<u>PAGE 19</u>
• <u>COMING EVENTS</u>	<u>PAGE 21</u>
• <u>CSCC MARKETPLACE</u>	<u>PAGE 29</u>
• <u>CORVETTE TRIVIA QUIZ</u>	<u>PAGE 35</u>
• <u>CORVETTE TRIVIA QUIZ ANSWERS</u>	<u>PAGE 37</u>
• <u>ADMINISTRIVIA</u>	<u>PAGE 38</u>

About the Cover: A C6 For the 6th Month ...
The Lingenfelter 660 HP C6 Corvette Z06 Package

2026 Officers

President
Todd DeSchepper
832-431-8115
president@* *

1st Vice President
Scott Applekamp
720-728-9179
1stvp@* *

2nd Vice President
Rick McGuffin
719-210-8929
2ndvp@* *

Secretary / Editor
Pete DeFelice
808-729-5777
secretary@* *

Treasurer
Katee Driscoll
719-510-9459
treasurer@* *

Governor
Walt Jenkins
719-337-1143
governor@* *

2026 Board Members

Gary Yale
719-659-9408
boardmember1@* *

Jodi DeSchepper
281-635-7314
boardmember2@* *

Mike Dittman
719-660-0494
boardmember3@* *

Diana Dittman
719-651-7405
boardmember4@* *

** coloradospringscorvetteclub.org

Archive Custodian - Larry Valentine
Merchandise - Tony Gonzalez
Webmaster - Walt Jenkins
Highway Beautification -
Gary Walters & Tony Bruszewski

Club And Meeting Information

Board Meeting Information

Monthly board meetings are usually held on the Tuesday prior to the monthly club business meeting.

The next board meeting:
6:00 P.M. Tuesday, June 30, 2026
Hosted by Mike Dittman
Location: Dittman Residence
11290 Cressman Drive, Peyton

Club Meeting Information

Monthly club meetings are held on the first Thursday of the month.

The next club meeting:
6:30 P.M. Thursday, July 2, 2026
Location:
Mike Maroone Chevrolet North
1570 Auto Mall Loop, Colo Springs

91 out of 337 Members attended the June Meeting

- | | | | |
|----------------------|---------------------|-----------------------|----------------------|
| 1. Gail Applekamp | 24. John Driscoll | 47. Gerald Ludke | 70. Aaron Taylor |
| 2. Scott Applekamp | 25. Katee Driscoll | 48. Ron Madd | 71. Tom Taylor |
| 3. Todd Barnhardt | 26. Marianne Duner | 49. Karl Mai | 72. Wayne Timura |
| 4. Luther Benson | 27. Wayne Ebert | 50. Dean Mattes | 73. Gerry Turner |
| 5. Seth Bertino | 28. Fred Fuller* | 51. Rick McGuffin | 74. Dave Ury |
| 6. Mike Bochnak | 29. Kristi Gonzalez | 52. Joel Midkiff | 75. Phyllis Ury |
| 7. Winnie Bochnak | 30. Tony Gonzalez | 53. Scott Moeller | 76. Tom Ury |
| 8. Tad Brown | 31. John Gue | 54. James Oates | 77. Vicki Ury |
| 9. Chris Capshaw | 32. Larry Hannapel | 55. Alta Olejnik | 78. Gwenda Valentine |
| 10. Jonathan Capshaw | 33. Doug Hantelman | 56. Pete Olejnik | 79. Larry Valentine |
| 11. Elaine Collins | 34. Joni Hantelman | 57. Don Ostrander | 80. Jeff Voltattorni |
| 12. Tim Collins | 35. Calvin Helus* | 58. Jodi Parr* | 81. Frank Walters |
| 13. Jim Covey | 36. Debra Helus* | 59. Deb Pennebaker | 82. John Wendt |
| 14. Stephanie Covey | 37. Barb Hoepfner | 60. Denise Phillips | 83. Jay Whalen |
| 15. Scott Cronk | 38. Tom Hoepfner | 61. Jerry Phillips | 84. Tanya Whalen |
| 16. Jack Davidson | 39. Tom Jackson | 62. Dana Rasic* | 85. Colleen Williams |
| 17. Pete DeFelice | 40. Walt Jenkins | 63. Joe Richardson* | 86. John Williams |
| 18. Nani De Felice | 41. Steve Kennedy | 64. Rob Sanders | 87. Gary Wilson |
| 19. Jodi DeSchepper | 42. Jeremy Klinger | 65. Jim Schmidt | 88. Jill Wilson |
| 20. Todd DeSchepper | 43. Bob Knowles | 66. Jeff Smith | 89. Craig Wisniewski |
| 21. Diana Dittman | 44. Brian Lakes | 67. Julia Smith | 90. Gary Yale |
| 22. Mike Dittman | 45. Mike Landry | 68. Mike Smith | 91. Joe Zaccagnino |
| 23. Steve Dombrowski | 46. Karen Logan* | 69. Nicole Tamburelli | |

* New Members

Guests this month: Jerry Griffin (Red 2025 Z06), Diane Taylor (Aaron's Spouse), Kevin Hunt (Silver 1999 Coupe)

Special thanks to this month's newsletter contributors:
Scott Applekamp, Mike Bochnak, Tad Brown, Mike Dittman, Brian Lakes, Rick McGuffin

JUNE MEETING MINUTES

-President Todd DeSchepper called the June 4th, 2026, meeting to order at 6:30 pm.

-As always, Todd expressed his appreciation to the Maroone Chevrolet North Team, and others for providing support and door prizes for our monthly meetings.

-CSCC now has **337** members. We remain the 3rd largest Corvette club between Venus and Mars.

-Todd next pressed the membership to volunteer to assist in all the many upcoming events.

-As a means to encourage volunteerism, Todd debuted the new plan to award member event participation by awarding 2 FREE tickets to the club Christmas Party. These will be awarded at the December meeting. The more events you volunteer for, the better your chances of winning those tickets. Names will be entered at each event. Our trusty Randomizer will select the winners.

-Todd reminded everyone about the NCCC Web Page, and the CSCC videos posted there on the Governor's Garage page.

-The CSCC Corvette of the Month photo on the CSCC Website for June is Jean Cantu with her 2016 Coupe. Each month will feature a picture of a different club member's Corvette. Send a photo of your Corvette if you'd like it to be selected for this new initiative.

-The official CSCC Facebook Page is growing with new content and photos added daily. It's for sharing club and Corvette-related topics, with the usual rules to keep it courteous. Moderators are Katee Driscoll and Scott Cronk.

Coming Events:

-Katee Driscoll & Rick McGuffin requested last minute volunteers and helpers for the June 13th Maroone Charity Corvette Show Register now!! See page **21**.

-Drive-Your-Corvette-to-Work Day is June 26. We're doing our Annual Bird Dog BBQ cars & lunch shindig. Diana Dittman has info on page **22**.

-Diana Dittman also has a Wine Cruise set for June 28 in the Canon City area ending in tasting, tour and picnic at Holy Cross Abbey Winery. See details on page **22**.

-This year's 4th of July Parade in Monument is set, with CSCC participants. It's organized by Rick McGuffin. The quota is full as of now but contact Rick if you're want to be on the alternates list.

2nd VP - Membership: Rick McGuffin

-Rick introduced SEVEN new club members (plus 2 spouses that couldn't attend) that joined this month, bringing our current total to 337 members. WoW!

-In addition, Rick introduced 3 Corvette owners as meeting guests at this meeting: Jerry Griffin, owner of a Red 2025 Z06, Diane Taylor, the charming spouse of Aaron Taylor, and Kevin Hunt, who cruises in a Silver 1999 Coupe.

Secretary Report: Pete DeFelice

-Pete gave an update on the condition of Larry Esquivel. Larry was in a rollover accident on North Powers, when his 1969 Mustang transmission locked up, forcing the car to roll three times. Larry had to be cut out of the wreckage. He's in fine spirits however albeit with a broken leg and a broken shoulder.

-Send your event photos and For Sale ads to Pete DeFelice for posting on the club website and the newsletter.

-No corrections to the May 2026 minutes were noted. Minutes were approved.

Treasurer's Report: Katee Driscoll

-Nothing significant to report, however as a reminder, Katee takes event payments by check, cash and Venmo.

-Katee's Venmo address is @kateedriscoll

Governors Report: Walt Jenkins

-Walt & Nancy Jenkins are off to the upcoming NCCC Convention in Syracuse NY later this month. Look for a post-convention report at the July meeting.

-Walt outlined all the regional Rocky Mountain Region Corvette events. He encouraged CSCC participation.

Past Events:

-Walt Jenkins taught 5 Corvette folks from the CSCC / RMR how to setup and use the Axware Timing System for Autocross events. He promised more sessions to follow.

-Mike & Diana Dittman gave an out brief on the Tom Hanon Concours Show. The club made a slight profit, and they thanked all the volunteers.

-Walt gave the Cone Zone 2026 autocross report, citing a record 40+ participants and total of 18 CSCC members. Plus, we had 2 Cone Zone videos shown at the meeting too. See more on pages **11-12**.

New Cars - Upgrades - Special News:

-Jerry Ludke picked up a 2019 Black on Black 2019 Grand Sport Coupe.



-Mike & Winnie Bochnak grabbed a 2026 Arctic White ZR1 via Museum delivery at Natl. Corvette Museum! See page **9** for more info.



-Meeting adjourned at 730pm

-Minutes recorded by Pete DeFelice



Upcoming Colorado Springs Corvette Club 2026 Calendar of Events

<u>Date</u>	<u>Event</u>	<u>Location</u>	<u>Point of Contact</u>
Jul 04	4 th of July Parade	Monument CO	Rick McGuffin
Jul 11	Highway Beautification	5510 Hwy 85-87	Gary Walters
Aug 08	CSCC Corvette Show	Metcalfe Park, Fountain	Seth Bertino
Aug 16	Annual Club Picnic	DeSchepper's Home	DeSchepper's
Aug 22	Inn at Garden Plaza Show	2520 International Circle	S. Applekamp
Aug 28-30	Silverthorne Weekend	Silverthorne Area	The Gonzalez's
Oct 18	CSCC Fall Autocross	Douglas County EVOC	Don Adametz
Nov 08	S'No Flakes Rally	Who Knows?	Brian Enger
Dec 19	CSCC Club Xmas Party	Phantom Canyon Brewery	Katee Driscoll

SEE ALL REGIONAL EVENTS ON OUR CLUB WEBSITE CALENDAR

Yet another friend leaves us ... Kathryn “Kathy” Jo Turner

June 25, 1947 – May 21, 2026



Kathryn Jo Holland Turner was raised by parents, TJ and Maxine Holland in the beautiful ranching community of Meeker, Colorado. She attended Meeker High School and was involved in many academics and activities including cheerleading, band, choir and drama. She graduated with honors in 1965. Kathy then attended Colorado State University, joined Kappa Alpha Theta sorority, and became a Cheerleader in her freshman year. In her senior year, Kathy was selected as Miss Colorado State University going on to become Miss Congeniality at the States Beauty Contest. She graduated from CSU in 1969 with a B.A. in Education. In 1995 she was honored as the “Distinguished Alumnus for the School of Liberal Arts.” On a cold December 28, 1969, in Meeker Kathy married one of her sororities “house boys,” Navy Ensign Gerry Turner.

Thus, began her “Navy Wife career” in Pensacola, Florida where Gerry was attending Aviation Officer Training. In 1973 Navy F-4 Pilot and Training Instructor, Gerry & Kathy returned to Denver, CO. After joining the Navy Reserves and 25 years as an Navy and Joint Intelligence Officer, now Captain Turner, retired in August 1999 as the Area Commander of Joint Reserve Intelligence for the Southwest United States.

Kathy began building her career in retail with May D&F (now Macys); and moved to Long Beach, CA to work at the Broadway Stores and Carter Hawley Hale the sixth-largest department chain firm in the United States. Kathy started as a Department Manager in Foundations, and then promotions to Assistant Buyer, Buyer, Assistant Store Manager, Store Manager and Assistant to the Vice President of Stores, Vice President of Training and Communications and onto a Corporate Executive Recruiter.

Seeing a “glass ceiling” at Carter Hawley Hale, Kathy and her co-worker Barbara Helstrom, founded Helstrom, Turner & Associates (HTA) specializing in Executive Recruiting for Retail Stores with five offices on the West and East coasts. After a very successful fourteen years, Kathy and her partner sold HTA to Korn Ferry, one of the largest recruiting and management consulting firms headquartered in Los Angeles operating in 111 offices in 53 countries employing 8,198 people worldwide. During the transition of HTA to Korn Ferry, Kathy was Managing Director of Global Retail.

While living in Los Angeles, Kathy was very active in community service to include: The first woman to serve as President of the Rotary Club of Los Angeles; the first woman Chair of the Board of Directors for Goodwill Industries of Southern California and Inland Empire; the first woman Chair of the Board of Directors for the Salvation Army of Greater Metropolitan Los Angeles whose Mission was “Others.” Kathy also served as a Member of the Board of Directors for the Orthopedic Hospital Foundation of Los Angeles and Meals on Wheels.

Kathy was charismatic and exhibited passionate leadership and social relationships. She received many leadership and individual awards for her business and community service. The Mayor of Los Angeles presented Kathy and Gerry with a Certificate of Appreciation for “. . . more than 25 years of community service . . . and are Treasures of Los Angeles.” Kathy and Gerry retired to Colorado Springs, CO in 2014 to be closer to their respective families.

Kathy Turner had been diagnosed with Vascular Dementia and peacefully passed away to be with the Lord God on May 21, 2026, with Gerry holding her hand. Her parents preceded her in death. She is survived by her husband Gerry Turner and sister Sally Merriam of Florence, CO. Owing many Corvettes throughout their lives, Kathy & Gerry have been members of the Colorado Springs Corvette Club since November 2015.

AUTO FILM SOLUTIONS

EXCLUSIVE 15% OFF AUTO FILM SOLUTIONS SERVICES FOR CSCC MEMBERS.

PROTECT

PROTECT WHAT DRIVES YOU ///

WINDOW TINT, CERAMIC COATINGS, PAINT PROTECTION FILM

INVESTING IN WINDOW TINT, CERAMIC COATINGS, AND PAINT PROTECTION FILM (PPF) IS A SMART DECISION FOR ANYONE LOOKING TO PRESERVE THEIR VEHICLE'S APPEARANCE AND LONGEVITY. WINDOW TINT REDUCES GLARE AND UV RAYS, PROTECTING BOTH YOUR INTERIOR AND SKIN FROM HARMFUL SUN EXPOSURE, WHILE ENHANCING PRIVACY AND ADDING A SLEEK LOOK.

CERAMIC COATINGS PROVIDE AN ADDITIONAL LAYER OF PROTECTION BY CREATING A HYDROPHOBIC SURFACE THAT RESISTS WATER SPOTS, BIRD DROPPINGS, AND ROAD SALTS, MAKING IT EASIER TO CLEAN AND MAINTAIN A GLOSSY FINISH. MEANWHILE, PPF OFFERS THE ULTIMATE SHIELD AGAINST PHYSICAL DAMAGE, SUCH AS ROCK CHIPS, ROAD DEBRIS, AND MINOR SCRATCHES, KEEPING YOUR PAINT PRISTINE WHILE HAVING EXCEPTIONAL SELF-HEALING PROPERTIES.

COMBINING ALL THREE—WINDOW TINT, CERAMIC COATINGS, AND PPF—ENSURES COMPREHENSIVE PROTECTION, HELPING PRESERVE YOUR VEHICLE'S VALUE AND APPEARANCE WHILE SAFEGUARDING IT FROM ENVIRONMENTAL FACTORS AND DAILY WEAR AND TEAR.



DETAILS MATTER ///

COLOR CHANGE WRAPS, CHROME DELETE, & MORE

TRANSFORM THE LOOK OF YOUR VEHICLE WITH OUR CHROME DELETE VINYL WRAPS AND CUSTOM VINYL ACCENTS DESIGNED TO CREATE A SLEEK, MODERN APPEARANCE. WHETHER YOU'RE LOOKING TO BLACK OUT CHROME TRIM, ADD STRIKING COLOR ACCENTS, OR ACHIEVE A DISTINCTIVE TO LOOK, WE OFFER A COMPLETE RANGE OF SERVICES TAILORED TO YOUR NEEDS. OUR HIGH-QUALITY VINYL WRAPS NOT ONLY ENHANCE YOUR VEHICLE'S STYLE, BUT ALSO PROTECT ITS SURFACES FROM WEAR AND TEAR.

STYLE



BRAND

DESIGN /// PRINT /// INSTALL

PERSONAL & PROFESSIONAL BRANDING

WE MANAGE EVERY STAGE OF YOUR WRAP, SIGNAGE, AND GRAPHICS PROJECT FROM START TO FINISH, ENSURING A STREAMLINED PROCESS AND EXCEPTIONAL RESULTS. OUR ADVANCED IN-HOUSE PRINTING TECHNOLOGY ALLOWS US TO CREATE CUSTOM SOLUTIONS FOR ANY NEED, FROM SIMPLE GRAPHICS TO WILD FULL HAND-ILLUSTRATED DESIGNS THAT ARE BOLD AND UNIQUE. WITH A TEAM OF CERTIFIED INSTALLERS TRAINED TO WORK WITH THE BIGGEST BRAND NAMES IN MATERIALS, WE ENSURE EACH INSTALLATION IS EXECUTED FLAWLESSLY AND PRECISELY.



15% DISCOUNT APPLIES TO CORVETTE MODELS OF CSCC MEMBERS. A 10% DISCOUNT WILL BE APPLIED FOR ALL NON-CORVETTE RELATED VEHICLES.

719.985.5633 www.autofilmsolutions.com

6075 Terminal Ave., Colorado Springs, CO 80915



My First Car

Want to tell the club about your first ride? Send me a short write-up and maybe a pic or two to be featured in upcoming newsletters

In 1976, the day I turned 16 couldn't come fast enough. I was at the DMV the moment that they opened. This was in Gunnison, Colorado. With my newly acquired license in hand freedom was mine! However, it was short lived. A few months later I ended up rolling my parents Ford Pinto.



With me having to pay for repairs money was very tight. I needed some cheap wheels.

Down the block, a neighbor had a 1969 Hugger Orange Chevelle SS 396 for sale at \$800. It was a beauty! It was NOT to be. There was no way I could afford that car. However, a friend told me about a 1965 six-cylinder Ford Mustang that a girl who just graduated was selling for \$150. Good news: I could afford that. Bad news: The car wasn't running. The clutch and brake pedal were smashed down against the floorboard. When starting the car, it burned so much oil that it blew smoke rings out of the exhaust. So, what do you do? You fix it. No U-tube videos to help either. I took the motor out and took it apart. When my Dad walked into the garage and looked around at all of the parts he said, "You are a dumb s.o.b. and you will never get this running again." Well, little by little I took parts to auto shop class and worked on them. I rebuilt the heads, installed new pistons and piston rings, and got new bearings. This was about a 3-week process. I didn't bring the car in as bad things tended to happen in auto shop class. So, I would work on the parts and take them home with me. I got everything put back together and into the car. Then the moment of truth came.....will it start up? I turned the key and it started right up. I did it. I looked at the exhaust and no more smoke rings. I still needed a bracket for the clutch and brakes, and the Ford dealer had one, but it was way too expensive. Onto the local salvage yard where I found one for \$2 that I had to take out of a wrecked Mustang.

My Dad did end up apologizing to me and told me he was proud that I had learned how to fix the car. He also said that by rolling the Pinto, it mellowed me out and helped me figure out how to get some "wheels" on my own. At 66 years old now and 50 years later I still have my '65 Mustang. My graduation tassel still hangs from the mirror. My visors still have the fuzzy red covers that my Mom made. You will see my high school Gunnison Cowboys decal on the back window... Hope to see you at coffee and cars!



BOCHNAK'S ZR1 MUSEUM DELIVERY



On May 29, 2026, Mike & Winnie Bochnak took delivery of their new Arctic White, 1065 HP Corvette ZR1 at a special ceremony at the National Corvette Museum. They were joined on the adventure by Mike & Diana Dittman. Many CSCC Members watched the event via the NCM Livestream. It's a great way to receive your brand-new Corvette that few experience!

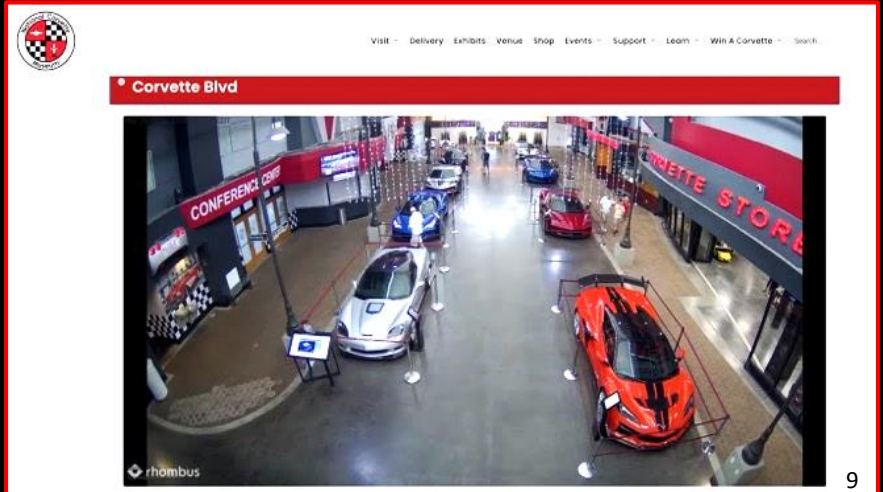



Insurance for your Corvette

Don't let insurance curb the fun of driving your sports car.

Sports cars have a tendency to be more expensive to protect, but it's possible to put the brakes on higher cost sports car insurance if you choose to **bundle** your existing home and auto insurance with insurance for your sports car.

What vehicles are considered sports cars?

Vehicles with higher horsepower tend to fall into the category of sports cars. Typically, these cars have two doors, sit closer to the ground and usually have two seats. There are different varieties of sports cars, such as the traditional sporty vehicles like Chevrolet Camaros or Corvettes, Dodge Challengers or Toyota Supras, and higher-end vehicles like Lamorghini, Ferrari and Porsche.



Debbie Vandel Insurance Agency
719-593-9200

Corvette Owner & CSCC Member

7610 N. Union Blvd, Ste 115
Colorado Springs, CO 80920

Debbie Vandel, Agent



CONE ZONE Autocross

2026

Cone Zone 2026 was held on a beautiful Colorado Sunday, with over 40 Corvette Autocross enthusiasts attending, joined by several "Metal" cars. The group descended on a very challenging autocross route at the Douglas County Emergency Vehicle Operations Course (EVOC). The cars were ready to attack the track with over 13 runs each for the day.



Walt Jenkins led the effort, designing the course and directing the whole afternoon. Todd DeSchepper graciously used his truck to bring the Club Equipment Trailer to the track. Many CSCC members participated in the track setup on the Saturday prior.



Lorren Loewen expertly ran the Timing duties for the day while Tom Hoepfner was Sunday's Grid Master, ensuring safe and timely starts for EIGHT hours. Barb Hoepfner handled distributing racers' time slips all day. Jodi DeSchepper and Barb handled all the many morning registrations. Pete DeFelice managed Donut Distribution.



Many first-time auto crossers participated too, using all four of the club's "spare" helmets while taking advantage of the "Free First Race for Newbies" policy. All remarked "I'll be Back!" after having a fun day.



Aside from their quick C6 Z06, Jeremy & Betsy Klinger brought their Autocross Mascot for moral support for all racers!



In addition, the CSCC's new Timing Gear performed flawlessly all day long too.



2026 CONE ZONE Autocross



We specialize in all types of factory or custom Corvette Wheels

2541 Platte Place
Colorado Springs CO 80909
Toll Free 800-538-6015
Office 719-659-8601
all alloywheelpro@Hotmail.com
<http://www.alloywheelpro.com/>

• Colorado Springs Wheel Repair Specialists

- Delivery and Pickup Available
- 1-Year Warranty
- State-Of-The-Art-Equipment
- (719) 659-8601

Opens 08:00 am



5% Discount for CSCC Members !

Curb Rash Straightening Welding Machining Polishing Custom Colors



Powder Coating

Our powder coating service provides a durable, high-quality finish that will keep your wheels looking their best. This process is environmentally friendly and offers a wide range of colors and finishes.

[Learn More](#)



Wheel Straightening

Our professional wheel straightening service can correct any bends, warps, out-of-round issues, and other deformities in your wheels, ensuring they are perfectly aligned and safe for the road.

[Learn More](#)



Wheel Repair

Our comprehensive wheel repair service can address a variety of issues, from cosmetic damage to structural problems, restoring your alloy, steel, or chrome wheels to their original condition.

[Learn More](#)



Wheel Welding

Our wheel welding service can repair cracks and breaks in your wheels, strengthening them and extending their lifespan. We are equipped to weld alloy, steel, and other wheel materials.

[Learn More](#)



Liquid Painting

Our liquid painting service offers a traditional approach to wheel finishing, providing a smooth, glossy finish that can be customized with colors and finishes that appeal to your preferences.

[Learn More](#)



CNC Machining

Our on-premises CNC machining service ensures precision and quality in every job, from wheel repair to custom modifications. We use state-of-the-art equipment to do the job right!

[Learn More](#)



Chemical Stripping

Our safe and effective chemical stripping service removes old paint and finishes from your wheels, preparing them for a fresh new look. This process works on a variety of materials.

[Learn More](#)



Mobile Service

Our mobile service brings our expertise to you, offering on-site repairs and wheel delivery services for your convenience. We work with dealerships and collision centers, too!

[Learn More](#)

Bowties on Broadway, 2026

Text by the Editor, Pix by numerous folks

On June 6th, a dozen or so CSCC Members ventured up I-25 to Elway's Chevrolet for their Annual Bowties on Broadway all-Chevy show, run by the Denver Corvette Association (DCA). It was a Peoples Choice affair.

"Bowties" was much much smaller than in the years past. Besides it's usual free hamburger / hot dog lunch, it featured only 2 Camaros, 3 trucks, and seven 50's-60's Chevy's. There was, however, lots of nice C2s, only 1 C3, 1 C4, 3 C5s, 1 C6, 3 C7s, and 10 C8s.

DCA awarded 3 trophies in each class. CSCC folks did extremely well garnering many of the trophies, to include:

Rob Sanders, Katee & John Driscoll and Mike & Winnie Bochnak scored in the C8 category.

Mike Landry, Rick McGuffin and Tad Brown all scored in the C7 group.

Bob Knowles snagged a trophy in the C5 class.



Bowties on Broadway, 2026 Winners



KATEE



BOB



TAD



MIKE



MIKE



RICK



ROB

Colorado Springs Corvette Club

Mike Maroone North's
Corvette Delivery
Specialist
Joel Olson - 480-413-6698

THANKS FOR
SUPPORTING
OUR MEMBERS AND
CAR SHOWS!



BONUS!

Every Month you show up
to a club meeting, you get
your name entered in the pot.

We will draw a name every
quarter for the "Corvette Club
Member of the Season"
(Spring, Summer, Fall, Winter)

You will also receive
a special prize!!



Exclusive Club Discounts:

20% OFF Express Services

15% OFF Main Shop Services

10% OFF Accessories



BOOK NOW!
719-867-2990

MikeMarooneColorado.com

**1570 Auto Mall Loop
Colorado Springs, CO
80920**

MAY 2026 REGIONAL EVENTS

On Saturday, May 16th, the Kiwanis Club Charity Car Show showcased many sweet, local cars and trucks. Approximately 70 vehicles of all types came to the show. CSCC had 11 entries at the event. A highlight of the day was the Beer Tent which made for a nice break as CSCC folks secured our own table. We had a great time swapping stories and telling lies jokes.



On Sunday, May 17th, TORCA's Show Us Your Chevy Car Show featured an impressive turnout, with more than 120 Corvettes on display. Among them, seven entries proudly represented CSCC. Notably, Mike Burks earned a 3rd place award in the C-3/C4 category, Jeff Markewich secured 3rd place in the C5 class, and Rick McGuffin achieved 3rd place in the C7 division. Although thunder showers threatened throughout the day, and many participants found themselves caught in the rain on their return home, the event was a resounding success. The variety of vehicles showcased, especially within the open Chevrolet classes, provided plenty of visual excitement and made for an unforgettable experience once again.

Our friends at Auto Film Solutions (AFS) held their first Cars & Coffee event on Sunday, May 17th. CSCC represented with five Vettes there, along with beautiful Ferrari's, Lamborghini's, GTR's, American Muscle cars, Euro and Japanese imports. AFS showcased their new facility with much of their work on display, while Under Pressure Performance and other vendors showed off too .





- REPLACEMENT PARTS
- PERFORMANCE PARTS
- DETAILING SUPPLIES

• CSCC MEMBERS USE **DISCOUNT CODE 3419318**

AND SHOW YOUR NCCC MEMBERSHIP CARD FOR 10% OFF

- WE HAVE REPLACEMENT PARTS AVAILABLE FROM OUR NATIONWIDE NETWORK
- WE CARRY A VARIETY OF PERFORMANCE PARTS
- BATTERIES – BELTS – BRAKES – ROTORS – WIPERS – POLISHES – FLUIDS – MORE!
- MANY STORES IN THE CSCC REGION **10% DISCOUNT FOR CSCC MEMBERS**
- O'REILLY REWARDS PROGRAM **SEE: [O'Reilly's Website](#)**



FREE Next Day Delivery

on 100,000+ products for orders \$35 or more.



FREE Pick Up In-Store

Order online and have your item(s) waiting for you at the store for pickup or curbside delivery.



Earn with O'Rewards

Earn points every way you shop. Earn faster by shopping limited-time bonus point offers.



Clear Wealth

M a n a g e m e n t

"Helping clients create financial clarity."



**Complimentary
Consultation
for CSCC Members**

**Jeffrey S.
Markewich**

JeffM@CreateClarity.US

www.CreateClarity.US

719-357-7747

Securities and Advisory
Services offered through LPL
Financial,
A registered investment
advisor

Member FINRA / SIPC

By the Editor and by Team ZR1

As of June 2026, the 2026 Corvette production is completed. GM now re-tools for 2027 models.

As many club members know, a few early C8 Corvettes had transmission reliability issues with its M1L dual-clutch automatic transmission. GM did a series of fixes, moving from Die 1 to Die 2. By the end of the 2023 model year, Chevrolet updated the Stingray's M1L eight-speed dual-clutch automatic, introducing a new Die 3 transmission case design. *Note: The C8 Z06 and E-Ray all use the heavy duty M1M Transmission with the Die 3-style case.*

Among other reliability improvements on C8 transmissions, GM made key changes in the transmission fluid sump pans. Here's how they are identified:

- Transmission Die 1: 2020-21 C8s used the original 15 Bolt, Die 1 cases with **stamped-metal** sump pans with rails.
- Transmission Die 2: 2022 and early 2023's C8's had improved Die 2 **cast aluminum** sump pans identified by 19 bolts.
- Transmission Die 3: The Die 3 case released in mid-2023 is identified by **four fasteners along the front edge of the sump pan**, replacing the six-fastener layout of the earlier Die 2 design.

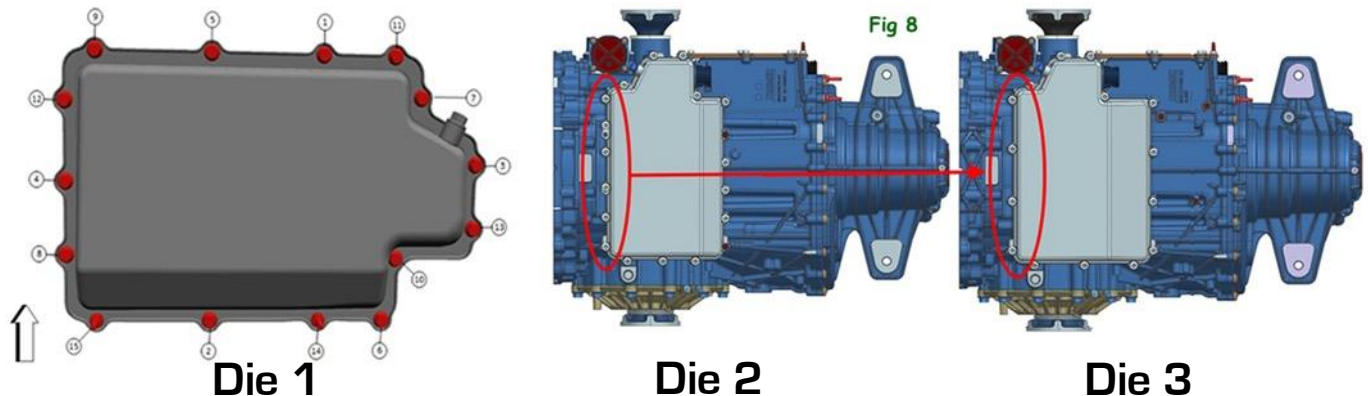

C8 Transmission Service / Replacement:

Repaired, replaced or remanufactured C8 dual-clutch transmissions are being upgraded to the Die 3 version, requiring additional parts for installation in older model C8s. For example, if your 2021 transmission fails, it'll be replaced by the new Die 3 transmission.

Track Fluid Requirement Change

- All Die 1 and Die 2 transmissions require **two** extra quarts of transmission fluid to be added for track use (per GM track prep guides).
- The newer Die 3 transmission cases no longer require the extra two quarts when used with the Z51 package for track days. The Z06 and the E-Ray use the Die 3 heavy duty M1M transmission.
- **Important: GM does not recommend track use of any M1L-equipped Stingrays without the Z51, package.**



WE CAN INSURE YOUR CLASSIC AUTO!

A PORTION OF THE PREMIUM FROM NEW OR TRANSFERRED POLICIES WILL BE DONATED TO THE CORVETTE CLUB FOR FUTURE EVENTS.



HAGERTY

PROGRESSIVE

Grundy
INSURANCE

AMERICAN COLLECTORS
INSURANCE

APPLY TODAY!

WE DO THE SHOPPING FOR YOU!

HOME

AUTO

COMMERCIAL

Call 719-867-8500

Or visit www.aaiaci.com



AMERICAN AFFORDABLE
INSURANCE



MIKE MAROONE CHEVROLET NORTH CHARITY

CORVETTE SHOW

SATURDAY JUNE 13 10AM - 2PM
1570 AUTO MALL LOOP, COLO SPRINGS

\$25 ENTRY FEE - PROCEEDS ARE MATCHED
AND DONATED TO VICTORY SERVICE DOGS



TROPHIES - FOOD TRUCKS - DOOR PRIZES - VENDOR DISPLAYS

Info: Katee - 719--510-9459 **VENMO:** @kateedriscoll
katee.driscoll@gmail.com

ALL CORVETTES WELCOME

Register: <https://www.corvettesnccc.org/NCCCOOnlineRegistration/Programs/Registration.php?eventId=559>





JUNE 26
DRIVE YOUR CORVETTE TO WORK DAY
 An annual event that encourages Corvette owners to drive their cars to work.

DRIVE-YOUR-CORVETTE-TO-WORK-DAY - JUNE 26TH

- Lead – Diana Dittman
- Celebrating Corvette’s 73rd Birthday
- Location - Bird Dog BBQ on Centennial Blvd
- 1130am-130pm
- Meet – Greet – Eat



WINE CRUISE TO THE ABBEY SUNDAY - JUNE 28TH



- Lead – Diana Dittman
- We will cruise first and then go taste wine at the Winery at Holy Cross Abbey in Canon City
- Bring a picnic lunch. We will be outside at tables set up for us
- Meeting Spot: Safeway on Hwy 115 and S. Academy Blvd
- Be there by 10:15. This is a casual short cruise
- We’ll cruise South on Hwy 115 through Florence and around to Canon City
- Next, we’ll proceed to Skyline Drive for an awesome view ... and Quick Stop for Pictures
- Then on to the Abbey ... *Please note* The Town of Penrose has ongoing highway construction. We will have to drive on the shoulder for several miles as we go through.

Option One:

Wine tasting only: order a Wine Flight for \$14 per flight. Premium Flight is \$20 per flight. This is on a walk-up basis

Option Two:

Includes a tour of the crushing facilities and a chance for guests to learn about the winemaking process.

The tour lasts 15 minutes and concludes before the wine tasting begins.

The Option Two package includes:

- The Tour
- Standard Wine Flight
- Discounted Food Options from the ala carte charcuterie menu
- 20% off coupon applicable to any wine and merchandise purchases
- This option is \$25 per person

NOTE - For Option Two, (the tour and wine tasting) we need a minimum of 8 people.

Wine tasting is open from 12-5 pm. 22



Corvette Show



COLORADO SPRINGS CORVETTE CLUB

**Metcalfe Park
618 East Ohio Ave.
Fountain, CO 80817**

**FREE TO THE PUBLIC
VOTE FOR YOUR FAVORITE CORVETTE**



need more info: Seth Bertino, 719-963-7412, seth.bertino@gmail.com

Corvette Entry Fee: \$25

Register Here:



saturday, august 8, 2026

10am - 2pm





CSCC Corvette Car Show



**Metcalfe Park
618 East Ohio Ave.
Fountain, CO 80817**

**Saturday, August 8, 2026 , 10am – 2pm
\$25 Entry Fee**



On-site registration 8:00am - 10:00am. Register Online at:



<https://www.corvettesnccc.org/NCCCOOnlineRegistration/Programs/Registration.php?eventId=560>

Online registration closes 11:00pm, Thursday, Aug 6th

VENMO payments can be made to @kateedriscoll

**Corvette Classes C1 thru C8, Best in Show, as voted on by the public
Food Service & Door Prizes**

**Sanction # RM-183-008
Chair – Seth Bertino, 719-963-7412, seth.bertino@gmail.com
Co-chair – Nicole Tamburelli, 719-859-0435, nikkijo2007@hotmail.com
Governor – Walt Jenkins, 710-597-2904, waltjenkins@comcast.net**

Non-NCCC members are not covered by NCCC insurance



CSCC Silverthorne Weekend 2026 **Car Show and Scavenger Hunt Rallye** August 28 - 30, 2026

Car Show (Saturday, 29Aug2026)

10am to Noon (setup at 0930)

Outlets at Silverthorne (246 V Rainbow Drive, Silverthorne, CO 80498)

Sanction Number: **RM-183-009**

The Peoples Choice Car Show allows entrants and attendees one vote each for their favorite Corvette

Chairpersons: Tony/Kristi Gonzalez

tgonzalez1@yahoo.com 719-659-4133

Scavenger Hunt Rallye (after Car Show, Saturday, 29Aug2026)

Meet at host hotel Quality Inn & Suites Silverthorne

Check in and tech-inspection 2 to 2:30pm

Drivers meeting: 2:30pm (Navigators required for event)

All cars out: 2:45pm. All cars return by 4pm

Sanction Number: **RM-183-010**

Search local area for items on list. Winner receives \$25 Gift Certificate

Chairpersons: Tony/Kristi Gonzalez

tgonzalez1@yahoo.com 719-659-4133

Cost: \$25 for each event or \$40 for both events

Event Registration opens: 3June2026

Online registration closes: Midnight 26Aug2026

Please register online if possible to avoid on-site registrations

<https://www.corvettesnccc.org/NCCCOnlineRegistration/Programs/Registration.php?eventId=14>

NCCC RULES WILL BE USED FOR THIS EVENT.
NON-NCCC MEMBERS ARE NOT COVERED BY NCCC INSURANCE.
ELECTRIC CARS ARE NOT ALLOWED UNLESS THEY ARE HYBRIDS.

Hotel Information:

Quality Inn & Suites Silverthorne – Copper Mountain

Address: 530 Silverthorne Lane, Silverthorne, CO, 80498, US

Phone Number: (970) 513-1222

Group Information:

Group Name: Colorado Springs Corvette Club

Group Account: EY39V9

Arrival Date - 08/28/2026

Departure Date - 08/30/2026

Room(s) Information and Rate(s):

10 Room(s) per night - 2 Queen Beds, Non-Smoking - \$160.00/rm per night + Tax

5 Room(s) per night - 1 King Bed, Non-Smoking - \$160.00/rm per night + Tax

Booking link: <https://www.choicehotels.com/reservations/groups/EY39V9>

Unbooked Room(s) release date: 21Aug2026

• WINDOW TINT



SUPERIOR
Heat Rejection

Book Now

• CERAMIC COATING



INSANE
Gloss and Chemical Protection

Book Now

• PAINT PROTECTION



SHIELD
Invisible Protection

Book Now

• DETAILING



SHIELD
Invisible Protection

Book Now



EXCLUSIVE 15% OFF FOR CSCC | www.j9sdetailing.com | 719-920-3290

3rd Saturday
10 - Noon

Clear Wealth
Management
Jeffrey S. Markewich
719-548-8103

Cars & Coffee



We'll have the coffee and doughnuts

Weather Permitting

Bring A Friend!
Rev Up Your Weekend

6385 CORPORATE DR. 80919
NORTH PARKING LOT



2026 NCCC NATIONAL CONVENTION

Syracuse NY, June 20 – 27, 2026

The NCCC “Governor’s Garage” podcast released several promotional videos to support the upcoming **67th Annual NCCC Convention in Syracuse, New York.**

These videos highlight competition, community, and the travel experiences surrounding Convention week.

Club Governors are encouraged to share these videos with their clubs and members through social media, newsletters, and club communications.

The more members who see these videos, the more awareness we create for Convention week.

CONVENTION VIDEO SERIES TO SHARE:

Governor’s Garage – Debbie Schafer Convention Interview:

<https://youtu.be/-eh4IXdyrxs?si=ksqmnRTIMlwzQoSf>

Episode Short: <https://youtu.be/iy8wAwqFGiU>

Short 1: <https://youtube.com/shorts/hSh2xfM3cgw>

Short 2: <https://youtube.com/shorts/NBII8CiRrQU>

Short 3: <https://youtube.com/shorts/LcPCloFM4Wl>

Short 4: <https://youtube.com/shorts/cUFKUHPGUdw>



The Governor’s Garage Page on the NCCC Website:

<https://www.corvettesnccc.org/YouTube/GovernorsGarage/>

Convention Information:

<https://www.corvettesnccc.org/2026Convention/Convention2026.php>

Registration Information:

<https://www.corvettesnccc.org/2026Convention/2026Registration/RegistrationInstructions.pdf>

PRO AUTO SPA

JUNE CSCC Specials: \$1000 Cut, Buff, Ceramic Coat!

20% off of all detailing services, powder coating, hydro-dipping, paintless dent removal
10% off tint and paint-protection-film

Paint Protection Film / Clear Bra

Partial Front End | \$1,295
Full Front End | \$2,295
Full Vehicle | \$6,500

Auto Detailing Interior

Coupe/Sedan | \$299
Midsize | \$349
Fullsize/SUV | \$399

Ceramic Coating

7 Year | \$1,790
Lifetime | \$2,290

Powder Coating

4 Wheels | \$795
MT & BAL | \$120

Window Tint

2 Front Windows | \$155
All Windows - no windshield | \$405
All Windows - with windshield | \$710

Dents / Hail Repair

Nickel size | Starting at \$165

Cerakote

Headers | \$175

* Prices listed are "Starting At" prices

ASK ABOUT OUR ADDITIONAL RESTYLING SERVICES

We donate 5% of Colo Springs Corvette Club Sales Back to the Club too!



719-259-2566 hello@proautospa.com

909 S Tejon St, Colorado Springs, CO 80903

Monday - Friday 8:00am - 5:00pm

www.ProAutoSpa.com

Our passion is helping people drive their dreams!

PRECISION, PASSION & PROTECTION FOR YOUR CORVETTE 28

2023 CALLAWAY SUPERCHARGED 2LT Z51 STINGRAY COUPE



Ordered and purchased from MacMulkin as a Callaway. Car was built and sent directly to Callaway by GM.

— **DETAILS** —

- Torch Red Exterior
- Black Leather Interior
- Competition Seats
- Carbon Fiber Interior Trim
- Magnetic Ride Suspension
- Borla S-Type Exhaust
- ACS Composites Front Splitter
- ACS Composites Side Skirts
- Callaway Ceramic Polished Wheels
- Callaway Supercharger Package with 687 HP and 643 Ft Lbs Torque
- Never Driven in Rain / Snow / Salt

— **PROVENANCE** —

- Original Owner
- Callaway Production Number 042
- Displayed by Callaway at the 2023 SEMA Show
- Still under Callaway warranty until February 2027
- Sale Includes all Callaway Documentation, GM Model, and Window Sticker



**HUGE PRICE DROP !
Asking \$89,000**

- 4,817 Original Miles

CSCC MARKETPLACE

The CSCC Marketplace makes no representations, or warranties regarding the items listed for sale in this newsletter. Please do not contact the Colorado Springs Corvette Club regarding the purchase or the specifications of these vehicles or parts. You should contact the selling party. This page is provided as a courtesy to our club members. The Colorado Springs Corvette Club is not responsible for, or does it make any claims, neither expressed, or implied, as to the mechanical condition, or specifications of any item listed.

2014 Corvette Stingray 3LT Auto - Asking \$43,995



DETAILS

Mileage - 21,083

Blade Silver Metallic

Grey Interior

3LT Package

2nd Owner

Memory Package

Heated / Ventilated Seats

Color Heads Up



**Contact - Scott Cronk
719-201-8070**

scottcronk03@gmail.com





C5 Chevrolet Corvette



C6 Chevrolet Corvette



C6 Z06 Chevrolet Corvette



C7 Chevrolet Corvette



C8 Chevrolet Corvette

We specialize in Corvettes. Our tuner specializes in fuel injection and forced induction.

We can help with your naturally aspirated or carbureted project too!

Need a baseline or a full tune on your Corvette? UPP has you covered either way!

We tune in-house on a Dynamometer capable of measuring 1800+WHP per axle.

Full dyno tunes are by appointment only, as we want to spend as much time with your

Corvette as needed to meet your goals.

Give us a call today for a comprehensive list of what we can tune, pricing and availability!

We offer sales and installation of complete twin turbo systems with custom fabricated compatible plumbing and fuel delivery systems

Our ASE Certified technicians are in-house fabricators that can design and build anything from intercooler piping to a full tube-frame chassis.

Whether it be a simple fix on a cracked manifold or a custom exhaust for your race car, we have the experience and resources to build whatever you need!

UPP now offers full tuning for C8s. We now use HP Tuners software to fine tune your C8



We now have our C8 twin turbo kit available for immediate installation! Contact us for pricing today

UPP offers the best in aftermarket suspension options. We are direct retailers for:

Belltech | Eibach | D2 | Koni | KW Suspension | KYB | RSR | Tein & More!
Our trained technicians can handle all of your suspension needs, from factory upkeep to full coil-over conversions.

CONTACT US

<https://uppturbo.com/>

6035 Terminal Ave Colorado Springs, CO

(719) 575-0202

sales@uppturbo.com

10% DISCOUNT FOR COLORADO SPRINGS CORVETTE CLUB MEMBERS

Brandon Ridenour CFP® and CRPC®

FREE Consultation and Investment Review for CSCC Members

FINANCIAL PLANNING

We employ a full suite of tools to completely round out your financial plan, including education, retirement, estate, and legacy planning.* We dig deep to not only identify what you want for your future, but to also understand how your circumstances are distinctive. This tells us how you will be best inclined to meet your plan. We revisit and revise long-term planning annually, ensuring your financial future is in step with your goals.

INVESTMENT MANAGEMENT

When building a portfolio, it is essential that we have a strong understanding of your risk tolerance, as well as how you plan on utilizing your assets over time. This allows us to customize your portfolio to your specific circumstances and needs. By providing a full financial analysis of your assets today and in the future, we are able to give advice on a wide variety financial topics as well as build a unique portfolio for your specific situation and desired outcomes.



bridenour@ffsinv.com | 283 Washington St. Monument, CO 80132

(719) 357-7189 www.ffsinv.com



Financial Action, inc. is a registered Investment Advisor. *Financial Action, Inc. does not provide legal or tax advice, we provide guidance and recommend professionals to complete these aspects of your financial plan. Certified Financial Planner Board of Standards Inc. owns these certification marks in the U.S., which it awards to individuals who successfully complete the CFP Board's initial and ongoing certificate requirements.



The CSCC Marketplace makes no representations, or warranties regarding the items listed for sale in this newsletter. Please do not contact the Colorado Springs Corvette Club regarding the purchase or the specifications of these vehicles or parts. You should contact the selling party. This page is provided as a courtesy to our club members. The Colorado Springs Corvette Club is not responsible for, or does it make any claims, neither expressed, or implied, as to the mechanical condition, or specifications of any item listed.

There are several Corvettes Available For Sale at Mike Maroone Chevrolet Today, including a Watkins Glen Gray 2017 Grand Sport coupe

***** Contact Joel Olson at Mike Maroone Chevrolet North ***
480-313-6698 or JOlson@mikemarooneauto.com**



**NEED WHEELS FOR YOUR
C7 TRACK TIRES?**



For Sale

**2017 Grand Sport
Wheels in Brushed
Silver**

Front wheels are 19 x 9.5

Rear wheels are 20 x 12

Excellent Condition

**No scratches or
blemishes**

**Huge Price Drop
Asking \$1000**

**Contact Ron Wynn at
719-337-9211**

CSCC Marketplace

The CSCC Marketplace makes no representations, or warranties regarding the items listed for sale in this newsletter. Please do not contact the Colorado Springs Corvette Club regarding the purchase or the specifications of these vehicles or parts. You should contact the selling party. This page is provided as a courtesy to our club members. The Colorado Springs Corvette Club is not responsible for, or does it make any claims, neither expressed, or implied, as to the mechanical condition, or specifications of any item listed.

- Unique Boyd Coddington polished wheels (73 Dreamwheel)
- 17x10.5. Fits standard Chevy bolt pattern of 5x4.75
- They are in very good shape. Originally on a '92 Corvette
- Two of them were bent but now been professionally straightened
- No serious blemishes
- Research on these and could only find an old brochure with a photo of them



You will not find these easily anywhere
Price is for all 4 complete with center caps

Asking \$800 Call Todd DeSchepper 832-431-8115

Looking for an experienced real estate broker?

Luther Benson

*Serving sellers and buyers for 35 years in the local market!
Colorado Springs Corvette Club member since 2017.*

*FREE no pressure consultations!
FREE Market Analysis!*

Phone & Text: 719-310-2404

Email: AccessREPros@gmail.com

See all homes on the MLS at lutherbenson.com

Experience
Matters:

Scan to get your
home's value:



- Proven extensive marketing provides maximum exposure for a quicker and higher sale
- Buyer Representation
- Broker Owner
- Over \$150,000,000 SOLD
- 5 Star Broker on Google, Realtor.com and Zillow.com



CSCC Marketplace

The CSCC Marketplace makes no representations, or warranties regarding the items listed for sale in this newsletter. Please do not contact the Colorado Springs Corvette Club regarding the purchase or the specifications of these vehicles or parts. You should contact the selling party. This page is provided as a courtesy to our club members. The Colorado Springs Corvette Club is not responsible for, or does it make any claims, neither expressed, or implied, as to the mechanical condition, or specifications of any item listed.

Driveway Ramps for Sale

- 48" Driveway Ramps
- 4 Pack Heavy Duty Rubber Curb Ramps for Cars, SUVs, Trucks
- Low Profile Design with Water Drainage Channel
- Garage & Sidewalk Transition Solution
- Includes hardware to bolt together
- Like new for \$100

Contact Tad Brown at:

719-650-5254 or tb427z06@live.com



2004 Z06 Shocks, still in the box

These OEM shocks were discontinued in 2014.

A search of GM dealers & GM parts depots reflects that there are none to be had anywhere.

These may be the only ones available in the USA?

2 - each 10339944 (GM part #) Front Retail \$198.34 each

2 - each 10333945 (GM part #) Rear Retail \$232.34 each. With tax \$931.99 total.

First \$800.00 takes them, my loss your gain.

Text me, if you want pictures of the factory sealed boxes.

Call Craig Wisniewski at 719-229-9313



TODACAR

At Todacar, we specialize in protecting and enhancing Corvettes inside and out. With over 20 years of experience, we offer premium Window Tint, Paint Protection Film (PPF), Ceramic Coating, Vinyl Wraps, Custom Upholstery, and Corvette Decals.

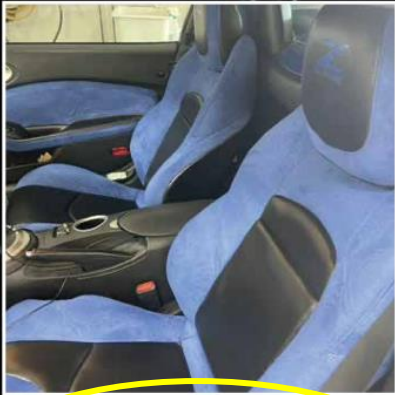

Need to Rebuild your seats? We got it!



Heat Protection on your Corvette? We Can Help!



Paint Protection on your new C8? Without a Doubt!



*Ceramic Coating?
A Must!*



*Custom Corvette
Decals? Of Course!*



*A full Body Vinyl Wrap?
Choose your Color!*

All CSCC Members get 15% discount!

(719)-491-1185



Call/Text for a quote today!



1. Answer: a; Yes, the “Blue Devil” was developed under secret code name “Project Blue Devil”, named after then GM CEO Rick Wagoner’s alma mater, Duke University. It became the first production Corvette to break the 200-mph barrier.
2. Answer: b; the C6 was the first Corvette to feature fixed (exposed) headlights since 1962. This change was driven by aerodynamics for the C6.R racing program, as pop-up headlights created significant drag.
3. Answer: a; the C6 ZR1 was the only C6 model to come with a factory supercharger. It produced 638 horsepower and 604 lb-ft of torque, making it the fastest and most powerful production Corvette at the time of its release.
4. Answer: b; No; the ZR1 nameplate took a 14-year hiatus after the C4 ZR-1 ended production in 1995 and did not return until 2009.
5. Answer: c; There are approximately 43 C6 Corvettes in our club, and it is awesome if you can let our officers know if you get a new or new to you Corvette to keep our count close.
6. Answer: d; The 2012 Centennial Edition celebrated Chevrolet’s 100th anniversary, featuring an exclusive Carbon Flash Metallic paint, satin-black wheels featuring a thin red stripe, red brake calipers, and unique branding honoring founder Louis Chevrolet.
7. Answer: b; False, 28,004 Grand Sports were produced in the C6 generation, they were available for the 2010 to 2013 model years, in either the coupe or convertible style.
8. Answer: b; No, There was no factory-produced C6 ZR1 convertible or removable roof offered from 2009 to 2013. All ZR1’s were exclusively offered as a fixed-roof coupe.
9. Answer: d; The 427 Convertible with 2,552 produced. There were approximately 142,000 base coupe and convertibles, 28,004 Grand Sports, 27,995 Z06s, and 4,684 ZR1s were produced in the C6 Corvette from 2005-2013.
10. Answer: c; 2007 had the highest number of C6’s produced, with 40,561 Corvettes. The lowest number was 2012 when 11,647 Corvettes were produced. Production of the C6 ended in 2013.

Bonus Question ...
Did you recognize this month’s
Flashback Photo Stars?

That’s none other than ...
Ralph & Keri Olson,
Owners of a Pair of C4
Convertibles



DO YOU WANT TO ADVERTISE? HAVE STUFF FOR SALE?
 Contact the CSCC Newsletter Editor & Club Secretary at pdef53@gmail.com

Size	Non-Member	CSCC Member
Business Card-size	\$10 per month \$100 per year	\$8 per month \$80 per year
¼ Page-size	\$15 per month \$150 per year	\$12 per month \$120 per year
½ Page-size	\$20 per month \$200 per year	\$16 per month \$160 per year
Full Page-size	\$30 per month \$300 per year	\$24 per month \$240 per year

Non-Members receive two free months when a full year is purchased
 Club members receive a 20% discount off non-member rates



ORLY'S ART GALLERY
 TOMAS MARTINEZ
 10% Off for CSCC Members
 (719) 630-3371
 CUSTOM FRAMING FINE ART SERVICES
www.orylartgallery.com
orylartgallery@qwestoffice.net
 OUR FRAMES MAKE YOUR CORVETTE PHOTOGRAPHS AND SHOW POSTERS EVEN MORE BEAUTIFUL

Colorado Springs Corvette Club, Inc.
P.O. Box 1986
Colorado Springs, CO 80901

Club Website
<https://www.coloradospringscorvetteclub.org/>



CSCC Email Distribution List

To send an email to the entire club click below:
cscvettes@googlegroups.com

All new members are added to the list using their email address from the Club roster.

For questions about the distribution list, please contact:
treasurer@coloradospringscorvetteclub.org

CSCC Email Etiquette

Please limit email use to Club and Corvette-related subjects, or items which may be of interest to the membership.

It is not intended for personal use, commentary, or to air grievances. If a member has a question about the appropriateness of a prospective email, the member needs to contact the Club President for guidance and/or approval.

In order to limit the number of unsolicited emails, when at all possible, please refrain from using the "Reply All" function, and only reply to the original sender.

NCCC National Council of Corvette Clubs Inc.

<https://corvettesnccc.org/>

NCCC Rocky Mountain Region (RMR) Website

[NCCC Rocky Mountain Region Website](https://www.coloradospringscorvetteclub.org/)

For a list of:

- Regional Officers and Clubs
- Expanded list of the Regional Calendar of Events
- Event Results
- Race Number Registration Form
- Rules and Forms
- NCCC News
- For more, please visit and stay informed

These links are also available on the CSCC web site at:
<https://www.coloradospringscorvetteclub.org/>

THE VETTE SET

Volume 63 Issue 8, June 2026

Colorado Springs Corvette Club, Inc.

Monthly Newsletter

WE MAKE VERY FEW CORVETTES LIKE THIS

Look closely. Those are cast aluminum wheels. They're one of several optional-at-extra-cost performance items Corvette supplies to the handful of enthusiasts who demand them.

If you want a 36.5-gallon gas tank, we have it. There are special performance equipment packages too. They include heavy-duty brake and suspension parts, and they're available only with the 375-hp Ramjet fuel-injected V8, 4-speed shift and Positraction equipment.

Why all these extra-cost options for a handful of enthusiasts? Well, we built the Corvette Sting Ray when we found that not everybody wants the same kind of car. And the options came in when we found that not everybody wants the same kind of Corvette. Options let you get just the Corvette you want. To the exact degree.

You can't fit people to the car. So we fit the car to the people.... Chevrolet
Division of General Motors, Detroit, Michigan. '64 CORVETTE STING RAY



CHEVROLET